

LARGE PARCEL & FREIGHT X-RAY IMAGING SYSTEM

XRC 85-85



The **XRC 85-85** x-ray machine facilitates the placement of heavy objects into the device with the help of **low conveyor unit**. It simplified the operators use thanks to the various image processing functions, hazard alarm, advanced computer technology and the best in class software. It makes it extraordinarily easy to scan threats such as cutting tools, explosive narcotics and reduces the rate of error.

It provides unique image quality by showing the scanned organic, inorganic and mixed items in different colors thanks to its multi-diode structure and quality in imaging of scanned objects. It is designed with the latest technology system to scan medium and large bags and packages.

This model x-ray device offers the ideal solution for locations where security screening is required like at high traffic checkpoints as city transportation (metro, ferry, train stations), customs border crossings, prisons, and courier depots, such as international logistics companies, goods acceptance points and etc.

TECHNICAL DATA XRC 85-85

PHYSICAL PROPERTIES

Tunnel Size	: 865 mm x 865 mm
(W x H)	: 34,06 in x 34,06 in
Dimensions	: 3070 mm x 1730 mm x 1275 mm
(L x H x W)	: 120,87 in x 68,11 in x 50,20 in
Approx. Weight Unpacked	: ~990 kg (2182 lbs.)
Conveyor Height	: 335mm (13,19 in)
Conveyor Load Capacity	: 200 kg (441 lbs.) Evenly Distributed
System Power	: 110/220V AC ± 10% 50/60 Hz, 8A/4A
Conveyor Speed	: 0,20 m/sec. Forward or Reverse

X-RAY GENERATOR & IMAGE PERFORMANCE

Steel Penetration ¹	: 37 mm guaranteed; 39 mm typical
Wire Resolution ¹	: 36 AWG guaranteed; 38 AWG typical
Anode Voltage	: 180kV, operating at 160kV
Tube Current	: 1,0 mA
Beam Direction	: Vertically downward
Article Separation	: Low Z, Medium Z, High Z to 0,5 Z Accuracy Organic, InOrganic, Metallic
Cooling	: Oil and forced air cooling

COMPUTER SPECIFICATIONS

Processor	: Intel® Core™ i5 (or superior)
Monitor	: 21,5" Flat LCD (or superior)
Memory	: 4 GB RAM (or superior)
Video Card	: 2 GB (or superior)
Hard Drive	: 1 TB (or superior)
USB Port	: 6 port (or superior)
Operating System	: Linux

OPERATING ENVIRONMENT

Storage / Operating Temperature	: -20°C to 50°C / 0°C to 40°C (-4°F to 122°F / 32°F to 104°F)
Relative Humidity	: 0% to 95% non-condensing
Duty Cycle 100% (24 Hours), No warm-up required	

OPTIONAL FEATURES

- Barcode Reader System
- External Camera Archiving
- Remote Viewing Station
- Recheck Station
- Network Supervisory System (NSS)
- Remote Access Connection
- Smart Card Login

OPTIONAL ACCESSORIES

- External UPS (For system)
- Operator Console (Open-Closed/Adjustable/I-stand)
- 21,5"- 27" Flat Monitor
- Input / Output Rollers
- Test Kit (STP/ASTM)
- Protective Cover
- Search Table
- Tray Return System (Motorized/Gravity)
- Inclined Conveyor
- Ultrasonic Rat Repellent
- Radiation Meter

HEALTH AND SAFETY

- All X-Ray Center Ltd products meet all applicable international health and safety regulations.
- US FDA Federal Standard 21CFR 1020.40
- Health and Safety at Work Act 1974-compliant 6 : Available
- Film Safety : ISO 1600 / 33 DIN
- CE Compliance : Certified
- FCC & IEC Compatibility: Available
- IP 20 Safety : Certified
- Maximum level of radiation the exterior panels come in contact with is 0.1 mR/hour

STANDARD IMAGE PROCESSING FEATURES

- Perfect View (Detail Enhancement) (PV)
- Edge Enhancement (EE)
- Pseudo Color (PS)
- Organic Materials (OM)
- Inorganic Materials (IM)
- Black & White (B/W)
- Inverse Colors (IN)
- High Penetration (HP)
- Variable Edge Enhancement (+E -E)
- Variable Density (+D -D)
- Variable Gamma (+G -G)
- Variable Color Separation (+C -C)
- Zoom (64x)
- Sniper Zoom
- Recall Previous Images
- Manual/Automatic Archive
- Annotated Archive
- Multi Energy Viewer (4 - 6 Color)
- Atomic Number Display (Z Value)

STANDARD FEATURES

- Programmable Function Keys
- Parcel Counter
- Date and Time Display
- Virtual Threat Image Projection (TIP)
- Organic/Inorganic Threat Alarm
- Operator Training Program (OTP)
- UPS (For Computer Supply)
- Multi Languages
- Self Diagnosis
- Generator Timer
- Automatic Stop Conveyor
- Bi-Directional Scanning
- Emergency Stop Buttons

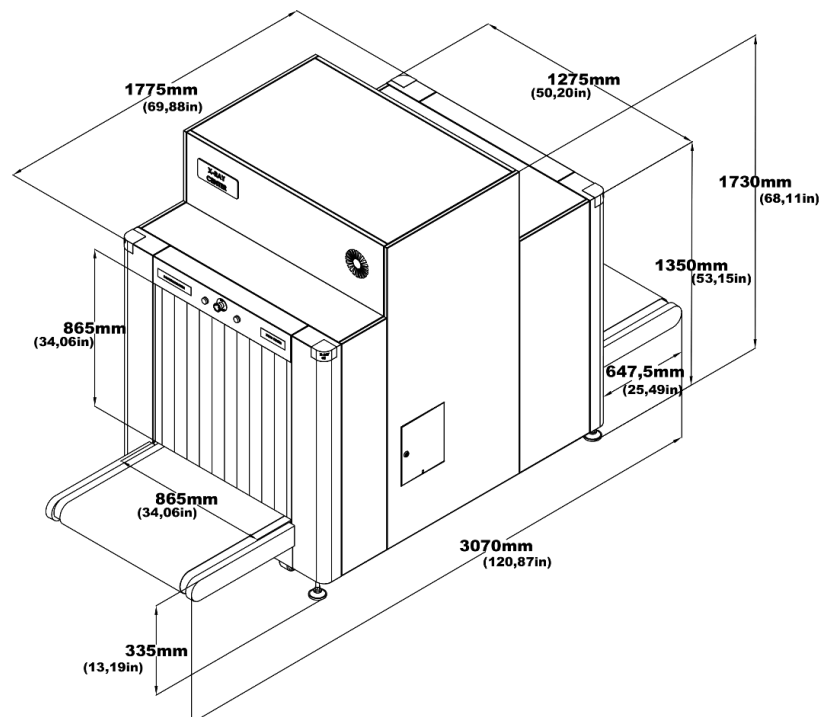

¹As tested on X-Ray Center Ltd. test piece. Conveyor speed is 0.20 m/sec.

