

SMALL PARCEL & BAGGAGE
X-RAY IMAGING SYSTEM

XRC 60-40P



XRC 60-40P model x-ray baggage scanner's various image processing functions, hazard alarm, advanced computer technology and the best in class software features facilitates the operators usage. It provides exceptional ease in detecting threats such as cutting tools, explosives narcotics and minimizes the error rate. Thanks to its multi-diode structure and quality in imaging of scanned objects, image is colored based on density and shows organic, inorganic and mixed materials in different tones.

This x-ray machine is a preferred model for locations with limited operating space and it is an efficient and a powerful device for scanning small handbags, packages parcels and cabin baggage in detail. Courts, police departments, offices, shopping malls, prisons and hotels are its main areas of application.

TECHNICAL DATA XRC 60-40P

PHYSICAL PROPERTIES

Tunnel Size	: 610 mm x 420 mm
(W x H)	: 24,02 in x 16,54 in
Dimensions	: 1472 mm x 1270 mm x 870 mm
(L x H x W)	: 57,95 in x 50 in x 34,25 in
Approx. Weight Unpacked	: ~425 kg (937 lbs.)
Conveyor Height	: 730 mm (28,74 in)
Conveyor Load Capacity	: 165 kg (364 lbs.) Evenly Distributed
System Power	: 110/220V AC ± 10% 50/60 Hz, 6A/3A
Conveyor Speed	: 0,20 m/sec. Forward or Reverse

X-RAY GENERATOR & IMAGE PERFORMANCE

Steel Penetration ¹	: 38 mm guaranteed; 39 mm typical
Wire Resolution ¹	: 40 AWG guaranteed; 42 AWG typical
Anode Voltage	: 170kV, operating at 147kV
Tube Current	: 0,7 mA
Beam Direction	: Vertically upward
Article Separation	: Low Z, Medium Z, High Z to 0,5 Z Accuracy, Organic, Inorganic, Metallic
Cooling	: Oil and forced air cooling

COMPUTER SPECIFICATIONS

Processor	: Intel® Core™ i5 (or superior)
Monitor	: 21,5" Flat LCD (or superior)
Memory	: 4 GB RAM (or superior)
Video Card	: 2 GB (or superior)
Hard Drive	: 1 TB (or superior)
USB Port	: 6 port (or superior)
Operating System	: Linux

OPERATING ENVIRONMENT

Storage / Operating Temperature	: -20°C to 50°C / 0°C to 40°C (-4°F to 122°F / 32°F to 104°F)
Relative Humidity	: 0% to 95% non-condensing
Duty Cycle 100% (24 Hours), No warm-up required	

HEALTH AND SAFETY

All X-Ray Center Ltd products meet all applicable international health and safety regulations.
 US FDA Federal Standard 21CFR 1020.40
 Health and Safety at Work Act 1974-compliant 6 : Available
 Film Safety : ISO 1600 / 33 DIN
 CE Compliance : Certified
 FCC & IEC Compatibility : Available
 IP 20 Safety : Certified
 Maximum level of radiation the exterior panels come in contact with is 0.1 mR/hour

OPTIONAL FEATURES

Barcode Reader System
 External Camera Archiving
 Remote Viewing Station
 Recheck Station
 Network Supervisory System (NSS)
 Remote Access Connection
 Smart Card Login

OPTIONAL ACCESSORIES

External UPS (For system)
 Operator Console (Open-Closed/Adjustable/I-stand)
 21,5" - 27" Flat Monitor
 Input / Output Rollers
 Test Kit (STP/ASTM)
 Protective Cover
 Search Table
 Tray Return System (Motorized/Gravity)
 Inclined Conveyor
 Ultrasonic Rat Repellent
 Radiation Meter

STANDARD IMAGE PROCESSING FEATURES

Perfect View (Detail Enhancement) (PV)
 Edge Enhancement (EE)
 Pseudo Color (PS)
 Organic Materials (OM)
 Inorganic Materials (IM)
 Black & White (B/W)
 Inverse Colors (IN)
 High Penetration (HP)
 Variable Edge Enhancement (+E -E)
 Variable Density (+D -D)
 Variable Gamma (+G -G)
 Variable Color Separation (+C -C)
 Zoom (64x)
 Sniper Zoom
 Recall Previous Images
 Manual/Automatic Archive
 Annotated Archive
 Multi Energy Viewer (4 - 6 Color)
 Atomic Number Display (Z Value)

STANDARD FEATURES

Programmable Function Keys
 Parcel Counter
 Date and Time Display
 Virtual Threat Image Projection (TIP)
 Organic/Inorganic Threat Alarm
 Operator Training Program (OTP)
 UPS (For Computer Supply)
 Multi Languages
 Self Diagnosis
 Generator Timer
 Bi-Directional Scanning
 Automatic Stop Conveyor
 Emergency Stop Buttons

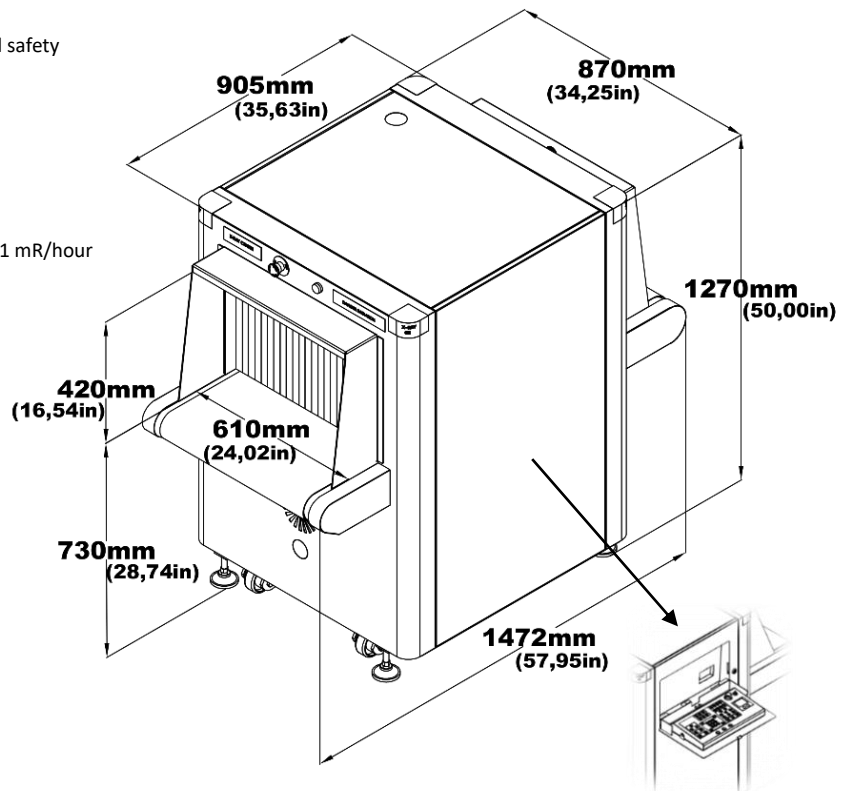

The keyboard can be produced optionally as integrated into the device.

¹As tested on X-Ray Center Ltd. test piece. Conveyor speed is 0.20 m/sec.
 Due to continuous product development, X-Ray Center reserves the right to change specifications without notice.

