

## SMALL PARCEL & BAGGAGE X-RAY IMAGING SYSTEM

# XRC 60-40DV



Quick and robust inspection is easily achieved with the XRC 60-40DV thanks to its **Liquid Explosive Detection Systems (LEDS) Standard 2 and Standard 3 Type C** issued by **European Civil Aviation Conference (ECAC)** and **American Transportation Safety Administration (TSA) ACSTL** certification. It facilitates the operators use thanks to the various image processing functions, hazard alarm, advanced computer technology and the best in class software and enables easy identification of potentially threatening objects such as cutting tools, explosives narcotics and minimizes the error rate.

It is designed with **dual view (DV)** technology. Thanks to its 2 x-ray generator sources, it provides high resolution and detailed imaging in horizontal and vertical angles. The images can be accessed with a single scan without the need to re-place the packages in a different orientation. Thus, hidden objects in the luggage are detected more easily and quickly. With the help of its multi-diode structure and quality in imaging of scanned objects, image is colored based on density and shows organic, inorganic and mixed materials in different tones. Small handbags, packages parcels and cabin baggage are suitable for scanning and offers the ideal solution for locations where security screening is required like airports checkpoints, police departments, ministries, prisons, institutions, courts, airlines, international customs logistics.

# TECHNICAL DATA XRC 60-40DV

## PHYSICAL PROPERTIES

Tunnel Size	: 620 mm x 420 mm
(W x H)	: 24,40 in x 16,54 in
Dimensions	: 2220 mm x 1370 mm x 1270 mm
(L x H x W)	: 87,40 in x 53,94 in x 50 in
Approx. Weight Unpacked	: ~675kg (1488 lbs.)
Conveyor Height*	: 800 mm (31,49 in)
Conveyor Load Capacity	: 165 kg (364 lbs.) Evenly Distributed
System Power	: 110/240V AC ± 10%
Conveyor Speed	: 0,20 m/sec. Forward or Reverse

## X-RAY GENERATOR & IMAGE PERFORMANCE

Steel Penetration <sup>1</sup>	: 37 mm
Wire Resolution <sup>1</sup>	: 38 AWG guaranteed; 40 AWG typical
Anode Voltage	: 160kV
Tube Current	: 1,0 mA
Beam Direction	: 1st Generator - Vertically upward 2nd Generator - Horizontally sideward
Article Separation	: Low Z, Medium Z, High Z to 0,5 Z Accuracy, Organic, InOrganic, Metallic
Cooling	: Oil and forced air cooling

## COMPUTER SPECIFICATIONS

Processor	: Intel® Core™ i5 (or superior)
Monitor	: Dual 21,5" Flat LCD (or superior)
Memory	: 4 GB RAM (or superior)
Video Card	: 2 GB (or superior)
Hard Drive	: 1 TB (or superior)
USB Port	: 6 port (or superior)
Operating System	: Linux

## OPERATING ENVIRONMENT

Storage / Operating Temperature	: -20°C to 50°C / 0°C to 40°C (-4°F to 122°F / 32°F to 104°F)
Relative Humidity	: 0% to 95% non-condensing
Duty Cycle	: 100% (24 Hours), No warm-up required

## STANDARD FEATURES

- Programmable Function Keys
- Parcel Counter
- Date and Time Display
- Virtual Threat Image Projection (TIP)
- Organic/Inorganic Threat Alarm
- Operator Training Program (OTP)
- UPS (For Computer Supply)
- Multi Languages
- Self Diagnosis
- Generator Timer
- Bi-Directional Scanning
- Automatic Stop Conveyor
- Emergency stop buttons

## OPTIONAL FEATURES

- Barcode Reader System
- External Camera Archiving
- Remote Viewing Station
- Recheck Station
- Network Supervisory System (NSS)
- Remote Access Connection
- Smart Card Login
- 3D Perspective View

## HEALTH AND SAFETY

All X-Ray Center Ltd products meet all applicable international health and safety regulations.

Safety Interlock Switches: To protect against radiation hazards In case of opening the sensitive lids of the machine, there are Safety Interlock Switches to prevent radiation leakage.

Made of strong materials and durable to scratch and rust.

US FDA Federal Standard 21CFR 1020.40

Health and Safety at Work Act 1974-compliant 6 : Available

Film Safety	: ISO 1600 / 33 DIN
CE Compliance	: Certified
FCC & IEC Compatibility	: Available
IP 20 Safety	: Certified

Maximum level of radiation the exterior panels come in contact with is 0.1 mR/hour  
*"The dimension of tunnel are project based"*

## STANDARD IMAGE PROCESSING FEATURES

- Perfect View (Detail Enhancement) (PV)
- Edge Enhancement (EE)
- Pseudo Color (PS)
- Organic Materials (OM)
- Inorganic Materials (IM)
- Black & White (B/W)
- Inverse Colors (IN)
- High Penetration (HP)
- Variable Edge Enhancement (+E -E)
- Variable Density (+D -D)
- Variable Gamma (+G -G)
- Variable Color Separation (+C -C)
- Zoom (64x)
- Sniper Zoom
- Recall Previous Images (100,000 or superior)
- Manual/Automatic Archive (100,000 or superior)
- Annotated Archive
- Multi Energy Viewer (4 - 6 Color)
- Atomic Number Display (Z Value)

## OPTIONAL ACCESSORIES

- External UPS (For system)
- Operator Console (Open-Closed/Adjustable/I-stand)
- 21,5" - 27" Flat Monitor
- Input / Output Rollers
- Test Kit (STP/ASTM)
- Protective Cover
- Search Table
- Tray Return System (Motorized/Gravity)
- Inclined Conveyor
- Ultrasonic Rat Repellent
- Radiation Meter

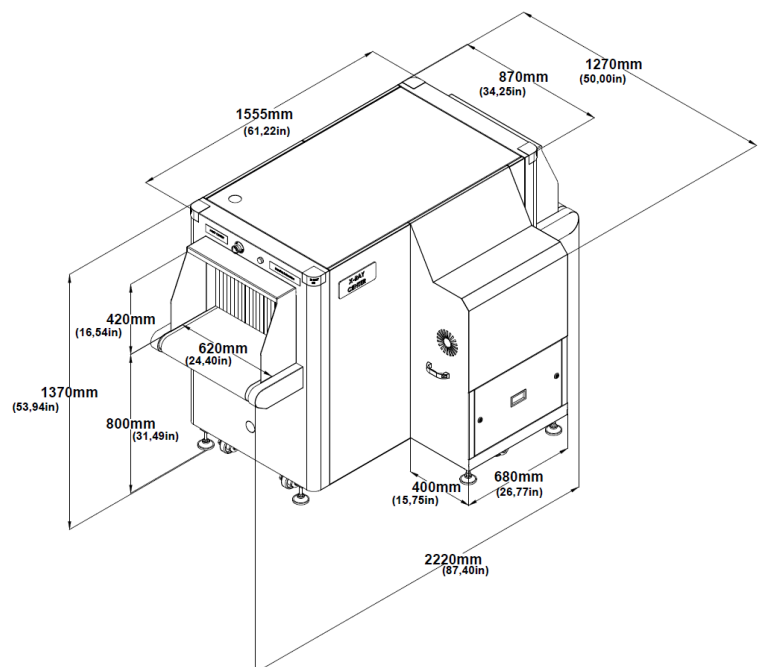

<sup>1</sup>As tested on X-Ray Center Ltd. test piece. Conveyor speed is 0.20 m/sec.  
 Due to continuous product development, X-Ray Center reserves the right to change specifications without notice.

